

**SDS / SDR LINEAR SLOT DIFFUSER - TYPE 9A
SUSPENDED CEILING TYPE**

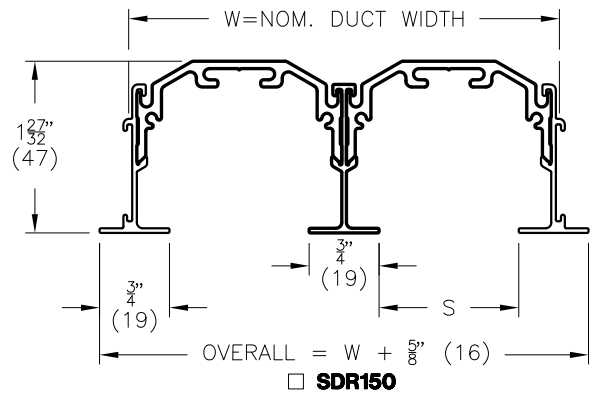
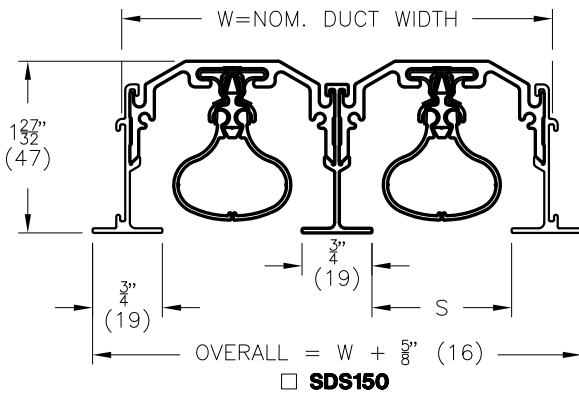
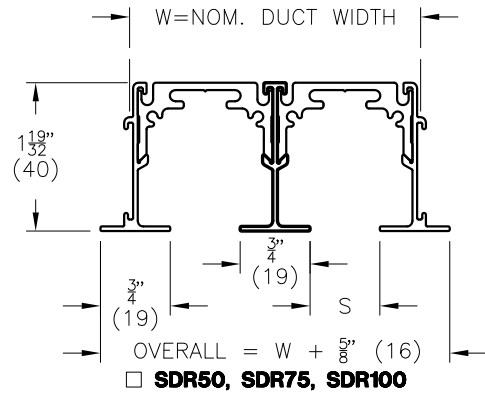
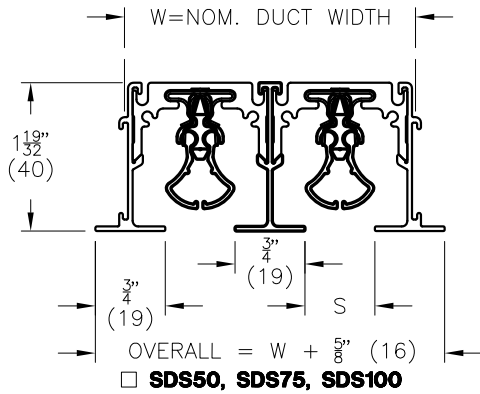

FINISH:

- PATTERN CONTROLLERS – B17 BLACK
- DIFFUSER FACE – B12 WHITE (OPTIONAL FINISHES AVAILABLE)

MATERIAL:

- EXTRUDED ALUMINUM FRAME
- EXTRUDED ALUMINUM PATTERN CONTROLLERS ON MODELS SDS50, SDS150
- ROLLFORMED STEEL OR EXTRUDED ALUMINUM PATTERN CONTROLLERS ON SDS75, SDS100

NOTE:

- MINIMUM LENGTH 8" (203)
- MAXIMUM SECTION LENGTH 72" (1829)
- UNITS 5 SLOT AND LARGER SUPPLIED WITH 1" (25) REINFORCING ANGLES ATTACHED TO DIFFUSER
- 180° AIR PATTERN ADJUSTMENT AVAILABLE
- FOR INTEGRATION WITH CEILING SUSPENSION SYSTEMS
- USE TYPE 14 SDA / SDB PLENUMS, OR UP / UPL
- FACTORY TOLERANCE ± 1/32" (1)
- SEE INSTALLATION INSTRUCTION I100045

MODELS:

- | | |
|------------------------|------------------------|
| SUPPLY DIFFUSERS: | RETURNS: |
| □ SDS50 – 1/2" SLOT | □ SDR50 – 1/2" SLOT |
| □ SDS75 – 3/4" SLOT | □ SDR75 – 3/4" SLOT |
| □ SDS100 – 1" SLOT | □ SDR100 – 1" SLOT |
| □ SDS150 – 1 1/2" SLOT | □ SDR150 – 1 1/2" SLOT |

ALL METRIC DIMENSIONS () ARE SOFT CONVERTED. IMPERIAL DIMENSIONS ARE CONVERTED TO METRIC AND ROUNDED TO THE NEAREST MILLIMETER.

PROJECT:		PRICE®
ENGINEER:		
CUSTOMER:		<i>MJ</i>
SUBMITTAL DATE:		235048
SPEC. SYMBOL:		2013/08/30
		SDS / SDR TYPE 9A LINEAR DIFFUSER SUSPENDED CEILING TYPE

**SDS / SDR LINEAR SLOT DIFFUSER - TYPE 9A
SUSPENDED CEILING TYPE**

END CONDITIONS:

W - FLANGE END

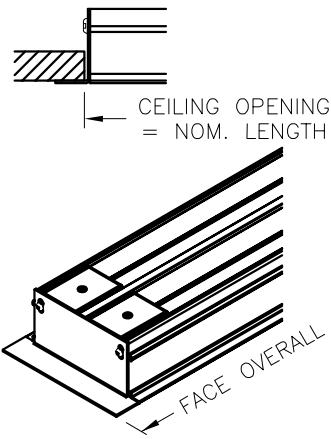

X - MITRED END

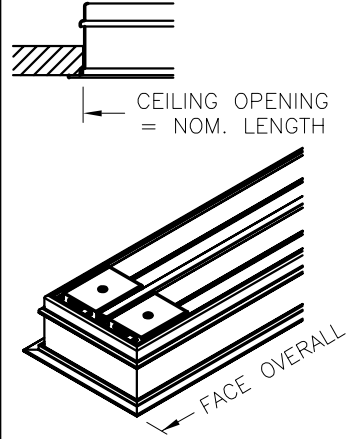

Y - OPEN END
FOR SPLICING TOGETHER
MULTIPLE SECTIONS

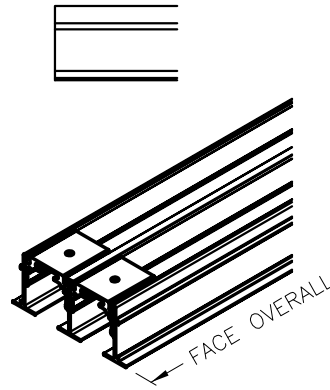

Z - FLUSH END CAP

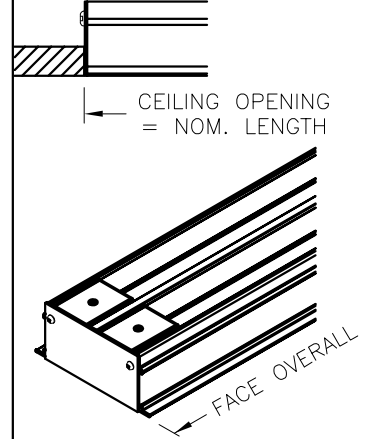

END CONDITION	FACE OVERALL LENGTH
W-W	NOM. LENGTH + 1 1/4" (32)
W-Y	NOM. LENGTH + 5/8" (16)
X-X	NOM. LENGTH + 5/8" (16)
X-Y	NOM. LENGTH + 5/16" (8)
Y-Y	NOM. LENGTH
Y-Z	NOM. LENGTH
Z-Z	NOM. LENGTH

SCREWHEADS EXTEND 1/8" (3) BEYOND
OPENING DIMENSION ON Z ENDS

MOUNTING:

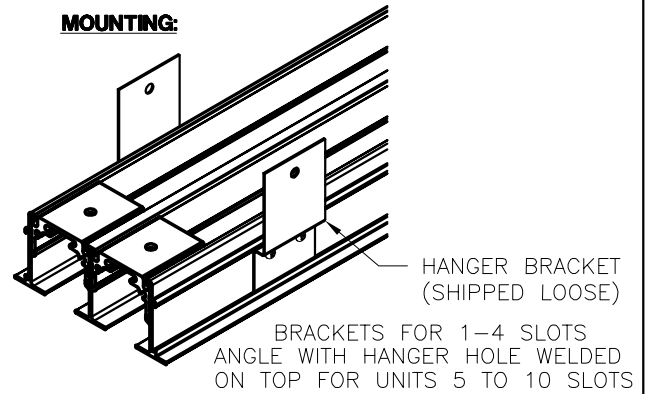

SLOTS	W			
	SDS50	SDS75	SDS100	SDS150
1	1 3/8" (35)	1 5/8" (41)	1 7/8" (48)	2 3/8" (60)
2	2 5/8" (67)	3 1/8" (79)	3 5/8" (92)	4 5/8" (117)
3	3 7/8" (98)	4 5/8" (117)	5 3/8" (137)	6 7/8" (175)
4	5 1/8" (130)	6 1/8" (156)	7 1/8" (181)	9 1/8" (232)
5	6 3/8" (162)	7 5/8" (194)	8 7/8" (225)	11 3/8" (289)
6	7 5/8" (194)	9 1/8" (232)	10 5/8" (270)	13 5/8" (346)
7	8 7/8" (225)	10 5/8" (270)	12 3/8" (314)	15 7/8" (403)
8	10 1/8" (257)	12 1/8" (308)	14 1/8" (359)	18 1/8" (460)
9	11 3/8" (289)	13 5/8" (346)	15 7/8" (403)	20 3/8" (518)
10	12 5/8" (321)	15 1/8" (384)	17 5/8" (448)	22 5/8" (575)

ALL METRIC DIMENSIONS () ARE SOFT CONVERTED. IMPERIAL DIMENSIONS ARE CONVERTED TO METRIC AND ROUNDED TO THE NEAREST MILLIMETER.

PROJECT:		PRICE [®]
ENGINEER:		
CUSTOMER:		235048
SUBMITTAL DATE:	SPEC. SYMBOL:	2013/08/30

SDS / SDR
TYPE 9A
LINEAR DIFFUSER
SUSPENDED CEILING TYPE